

# THE NEW STANDARD FOR INDUSTRIAL MOTORS

## Get in touch

The VIDAR team of experts is available for product questions and purchase inquiries. Get started on your VIDAR journey today and experience the benefits of significant energy, cost, and environmental savings.

Call +1 315 234 1973  
Email [vidar@itt.com](mailto:vidar@itt.com)

Get in touch with a member of our sales team to discuss your facility's unique needs and how VIDAR can benefit your business.

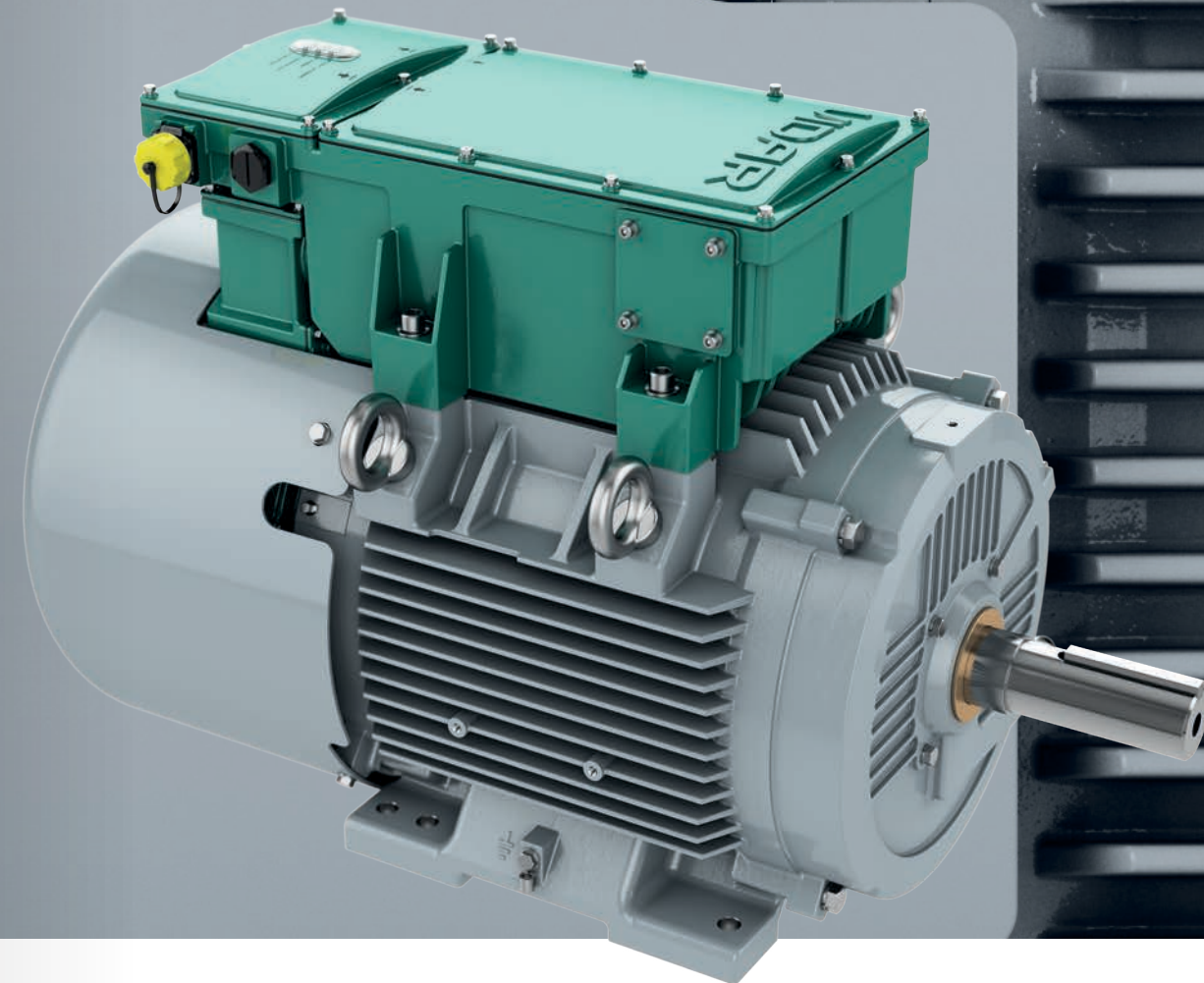

# Purpose Built for Industry

VIDAR embeds variable-speed intelligence directly into the motor, eliminating inefficient, failure-prone systems that rely on throttled valves and dampers. Unlike traditional VFD<sup>(1)</sup> and motor setups, it requires no special inverter-duty wire, additional enclosures, or extra floor space.



## One-to-one replacement

VIDAR installs seamlessly into the footprint of a conventional NEMA motor.<sup>(2)</sup>



## Precision control

VIDAR adapts to variable demands, giving plant managers unparalleled flexibility.



## Unmatched efficiency

VIDAR uses only the energy required for the job, cutting energy consumption and CO<sub>2</sub> emissions by up to 50%.<sup>(3)</sup>



## Customer-centric design

From easy installation to modular repairs, VIDAR was built for the people who use it.



## Durability and reliability

Designed to thrive in harsh outdoor industrial environments, VIDAR meets stringent industrial reliability and safety standards.

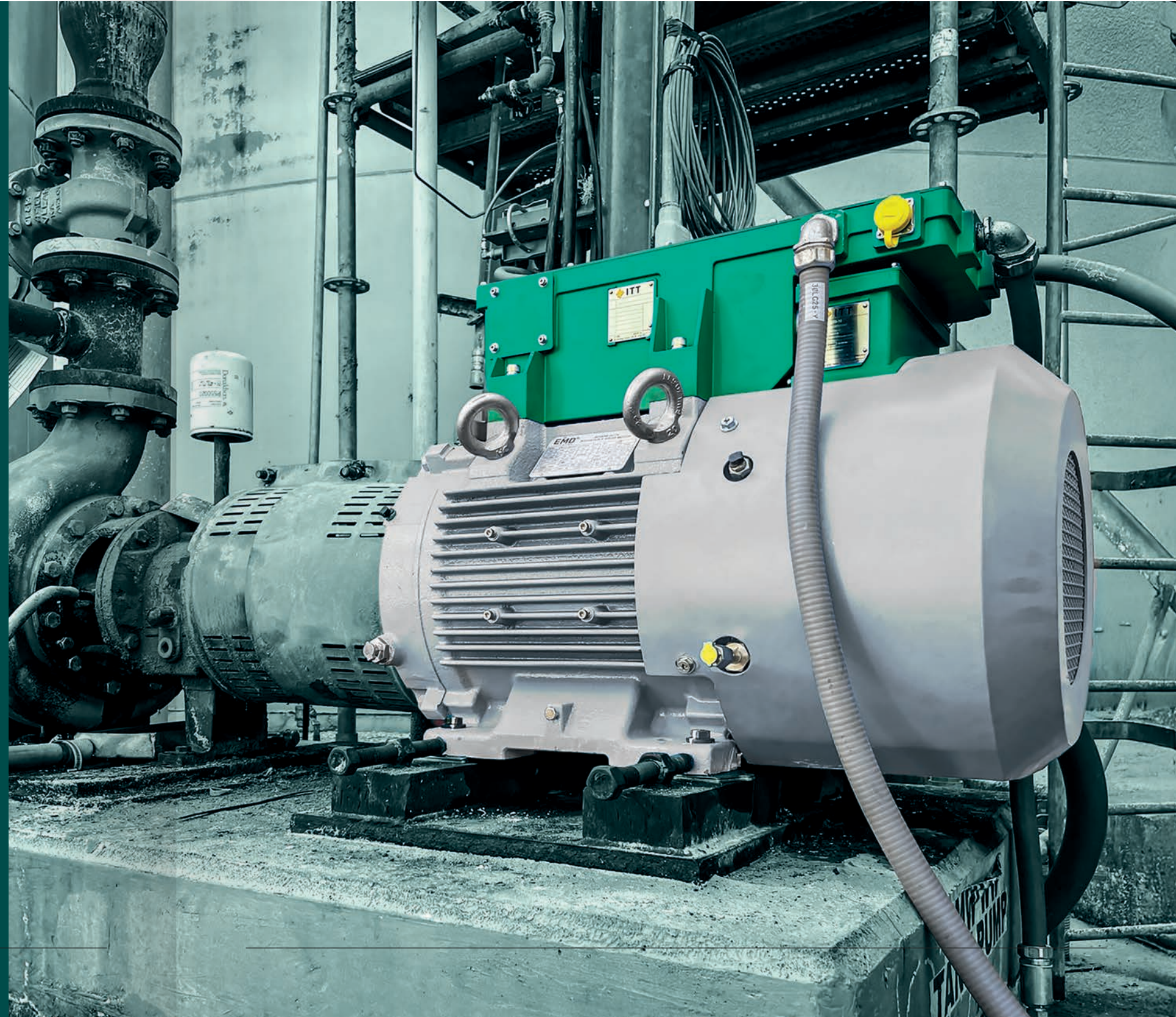

# Top 5 Reasons

VIDAR should be your next industrial motor

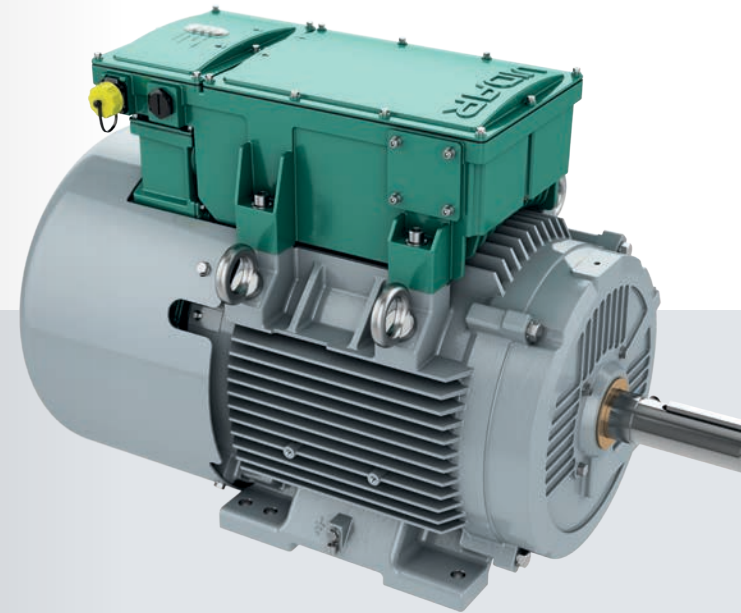

Here are five reasons why VIDAR should be your next industrial motor.

VIDAR is a new type of motor that embeds variable-speed intelligence directly into the motor to achieve new levels of performance, reliability, and simplicity in industrial applications involving pumps, fans, and fluid process systems. VIDAR's patented AC-Link technology replaces conventional AC-to-DC-to-AC VFD technology with a streamlined AC-to-AC approach.

Purpose-built for industrial facilities, VIDAR delivers dependable performance even in the toughest environments. VIDAR features a high-efficiency synchronous reluctance magnet-assisted motor designed using IEEE-841 specifications, meets CSA Class 1 Division 2 for hazardous areas, and meets IEEE-519 power quality standards.

The VIDAR motor is the culmination of years of listening to customers, collaborating with world-class researchers, and thousands of hours of rigorous testing in a variety of harsh industrial environments.



## 01 Save space with simplified installation

By removing the DC stage, VIDAR eliminates bulky capacitors, shrinking the VFD by 60%. The motor and VFD can be combined into a single, compact solution that installs seamlessly into the footprint of a conventional motor. Unlike traditional setups, VIDAR requires no special wiring, additional enclosures, or extra space. Installing VIDAR can be completed in less than an hour.



## 04 Enhance operations

VIDAR's precise motor speed control ensures consistent flow rates, improves product quality, and seamlessly adapts to changing workloads for greater operational flexibility and cost-efficient scalability. VIDAR operates at optimal speeds, prolonging the lifespan of the motor itself and associated equipment.



## 02 Improve energy efficiency

Unlike conventional motors that often run at full speed regardless of demand, VIDAR operates at variable speeds, using only the energy required for the task. This reduces energy use and CO<sub>2</sub> emissions by up to 50% as compared to a fixed speed motor with mechanical controls, lowering environmental impact, ensuring compliance with emissions regulations, and improving sustainability credentials.



## 05 Reduce downtime

VIDAR's modular design simplifies maintenance to just three components, and with integrated intelligence, the likelihood of breakdowns and the need for routine maintenance are greatly reduced. VIDAR is built for even the harshest industrial environments, ensuring that plants stay operational when it matters most.

VIDAR's innovative design unlocks energy and cost saving potential by addressing common barriers to efficiency and reliability that have impacted the industry for years. For your next project, consider the motor that does more than just power pumps and fans. VIDAR will transform your plant operations, giving you another reason to believe.



## 03 Eliminate mechanical controls

Throttled valves and dampers are inherently inefficient, leading to energy waste and high operational costs. VIDAR integrates variable-speed intelligence directly into the motor, reducing reliance on mechanical controls for fluid delivery systems, which directly translates into lower utility bills and reduced maintenance costs.



1. Variable Frequency Drive.

2. VIDAR meets the critical dimensions for foot-mounting and shaft location as defined by NEMA standards. Overall length may extend 4 to 6 inches depending on frame size.

3. Results are based on VIDAR cases studies - actual results are application dependent and may vary.

# Case Studies

## 01 Reduce energy and lower maintenance

### Eliminate mechanical controls

**Challenge:** A chemical plant was incurring \$18,000 annually on valve maintenance and experiencing significant energy waste.

**Solution:** The control valve was eliminated, and the fixed-speed motor was replaced with the VIDAR solution.

**Results:** \$33,000 in annual energy and maintenance savings.

Transform  
how your  
factory runs

### Average Annual Spend

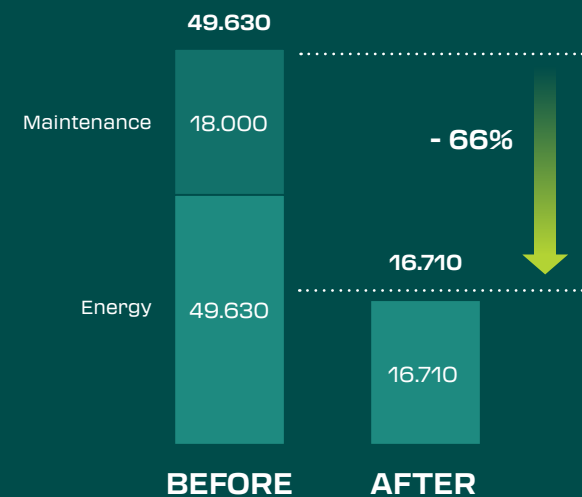

### Total Installed Cost

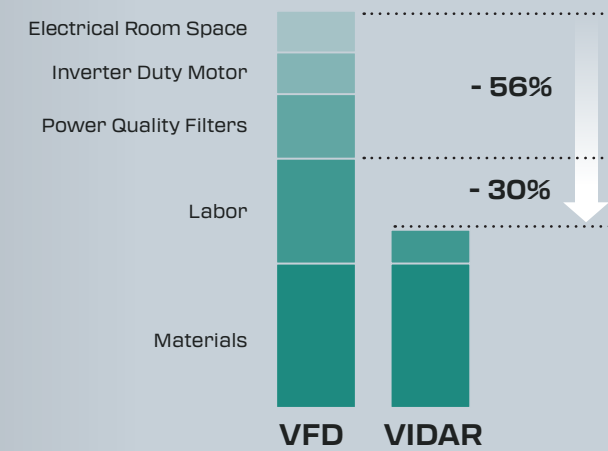

## 02 Easily upgrade to variable speed

### Save space and cost

**Challenge:** Conventional VFD systems, when installed separately, take up significant space and require complex installation.

**Solution:** The all-in-one design of VIDAR eliminates the need for additional space and simplifies the installation process.

**Results:** The total installed cost of VIDAR can be up to 30% less than a VFD in an industrial facility. When considering VIDAR's additional benefits, the cost reduction can exceed 50%.

## 03 Get more out of existing equipment

### Increase scalability and flexibility

**Challenge:** A grain milling operation needed to increase the air flow of its dust collection fan by 10% to accommodate a rise in production.

**Solution:** The VIDAR motor, operating at speeds 25% higher than a direct-online motor, was installed to boost the dust collection fan's speed.

**Results:** This solution achieved a 10% increase in air flow, utilizing the existing equipment.



VIDAR's patented AC-Link technology replaces conventional AC-to-DC-to-AC VFD technology with a streamlined AC-to-AC approach. By removing the DC stage, bulky capacitors are eliminated, shrinking the VFD by 60%<sup>[4]</sup>, enabling the motor and VFD to be combined into a single, compact solution.



## AC-Link technology

**01**

**Compact and integrated**

By removing the need for the DC stage, VIDAR shrinks the size of the power converter by 60% compared to comparable VFDs.

**02**

**Increased reliability**

The elimination of electrolytic capacitors removes a major failure point, resulting in a more durable and long-lasting system.

**03**

**Ultra-Low harmonics**

VIDAR's design minimizes harmonic distortion, maintaining power quality in compliance with IEEE-519 standards.

**04**

**Seamless integration**

With its compact design, VIDAR eliminates long cable runs between the VFD and motor, resulting in longer motor insulation life.

4. Based on equivalent VFD that provides ultra-low harmonic or regenerative capabilities.

### Conventional VFD power conversion

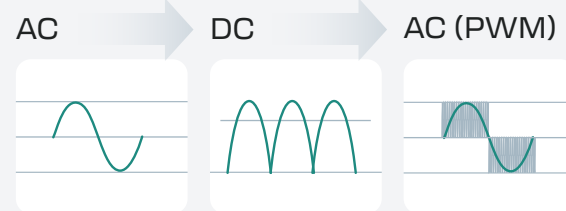

**VS**

### VIDAR

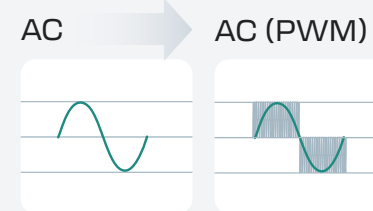

VIDAR is purpose-built for industrial facilities. It uses a high-efficiency synchronous reluctance magnet-assisted motor designed using IEEE-841 specifications, meets CSA Class 1 Division 2 for hazardous areas and meets IEEE-519 power quality standards for dependable performance even in the toughest environments.

## Synchronous Reluctance Magnet-Assisted (SRMA) Motor

**01**

**SRMA Design**

The VIDAR motor combines reluctance torque with permanent magnet assistance, eliminating rotor-induced currents for higher efficiency and power density.

**02**

**Lower operating temperature and higher efficiency**

Operating 10-25% cooler than induction motors, VIDAR reduces energy losses, extends component lifespan, and enhances reliability.

**03**

**Optimized torque and performance**

Its advanced magnetic design delivers superior efficiency, higher torque, and a better power factor, reducing energy consumption in industrial applications.

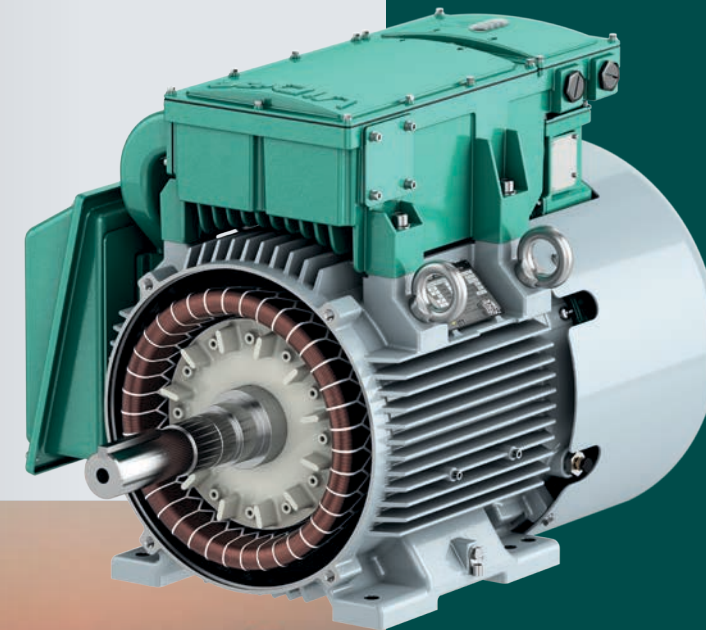

# Innovation Meets Durability

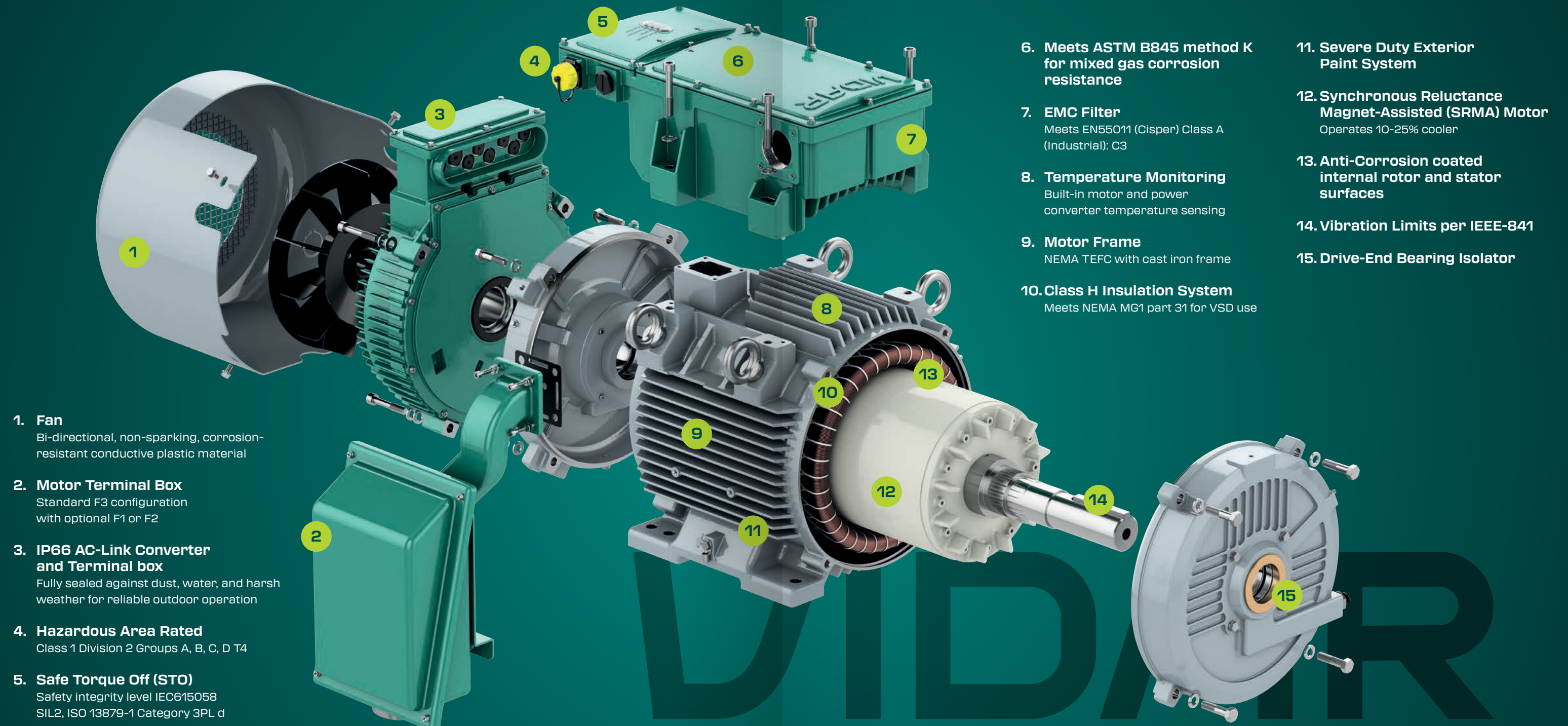

- 1. Fan**  
Bi-directional, non-sparking, corrosion-resistant conductive plastic material
- 2. Motor Terminal Box**  
Standard F3 configuration with optional F1 or F2
- 3. IP66 AC-Link Converter and Terminal box**  
Fully sealed against dust, water, and harsh weather for reliable outdoor operation
- 4. Hazardous Area Rated**  
Class 1 Division 2 Groups A, B, C, D T4
- 5. Safe Torque Off (STO)**  
Safety integrity level IEC615058 SIL2, ISO 13879-1 Category 3PL d

- 6. Meets ASTM B845 method K for mixed gas corrosion resistance**
- 7. EMC Filter**  
Meets EN55011 (Cispr) Class A (Industrial): C3
- 8. Temperature Monitoring**  
Built-in motor and power converter temperature sensing
- 9. Motor Frame**  
NEMA TEFC with cast iron frame
- 10. Class H Insulation System**  
Meets NEMA MG1 part 31 for VSD use
- 11. Severe Duty Exterior Paint System**
- 12. Synchronous Reluctance Magnet-Assisted (SRMA) Motor**  
Operates 10-25% cooler
- 13. Anti-Corrosion coated internal rotor and stator surfaces**
- 14. Vibration Limits per IEEE-841**
- 15. Drive-End Bearing Isolator**

# Technical Data

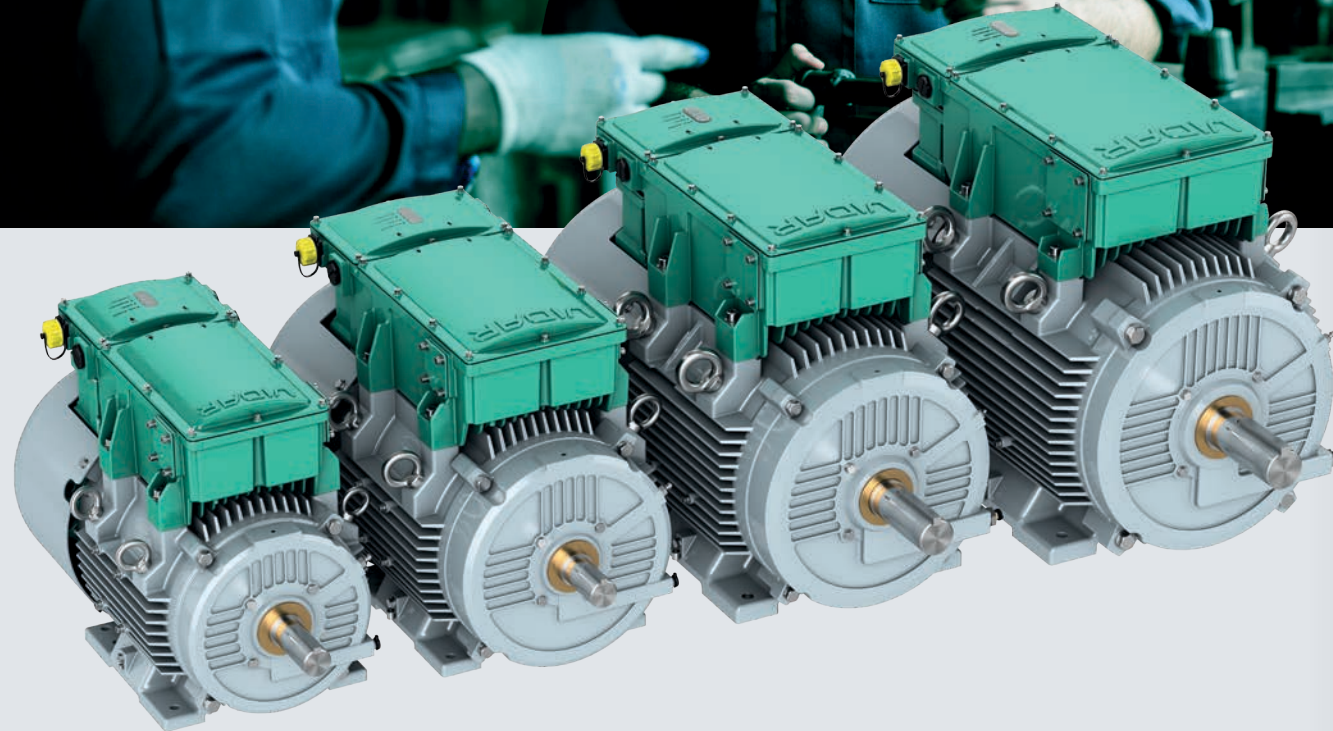

## Ratings

OUTPUT	BASE SPEED	MAX. SPEED	FRAME	PRODUCTNUMBER	'C' DIM.	INPUT CURRENT	INPUT THDI	MOTOR EFF.	PDS* EFF.	POWER FACTOR	WEIGHT
HP	RPM	RPM	NEMA		IN.	AMPS	%	%	%		lbs
20	3600	4500	254/6T	EMDX020H36EXA3ABAA	28.32	20.1	< 5%	93.6%	90.6%	0.99	364
20 / 10	1800 / 1200	2500	254/6T	EMDX020H18EXA3ABAA	28.32	20.3 / 10.4	< 5%	93.8%	90.8%	0.99	321
25	3600	4500	284/6TS	EMDX025H36EXA3ABAA	30.30	25.2	< 5%	94.3%	91.1%	0.99	459
25 / 15	1800 / 1200	2500	284/6T	EMDX025H18EXA3ABAA	31.67	25.1 / 15.6	< 5%	94.8%	91.9%	0.99	507
30	3600	4500	284/6TS	EMDX030H36EXA3ABAA	30.30	30.3	< 5%	94.4%	91.2%	0.99	507
30 / 20	1800 / 1200	2500	284/6T	EMDX030H18EXA3ABAA	31.67	30.1 / 20.8	< 5%	94.9%	92.0%	0.99	551
40	3600	4500	324/6TS	EMDX040H36EXA3ABAA	33.74	40.2	< 5%	95.5%	92.2%	0.99	551
40 / 25	1800 / 1200	2500	324/6T	EMDX040H18EXA3ABAA	35.24	40.1 / 26.0	< 5%	95.8%	92.6%	0.99	635
50	3600	4500	324/6TS	EMDX050H36EXA3ABAA	33.74	50.2	< 5%	95.7%	92.4%	0.99	633
50 / 30	1800 / 1200	2500	324/6T	EMDX050H18EXA3ABAA	35.24	50.1 / 31.2	< 5%	96.0%	92.8%	0.99	716
60	3600	4500	364/5TS	EMDX060H36EXA3ABAA	36.25	60.6	< 5%	96.1%	92.6%	0.99	800
60 / 40	1800 / 1200	2500	364/5T	EMDX060H18EXA3ABAA	38.37	60.3 / 41.6	< 5%	95.8%	93.3%	0.99	890
75	3600	4500	364/5TS	EMDX075H36EXA3ABAA	36.25	75.5	< 5%	96.2%	93.1%	0.99	888
75 / 50	1800 / 1200	2500	364/5T	EMDX075H18EXA3ABAA	38.37	75.4 / 51.5	< 5%	95.9%	93.4%	0.99	981

\* Power Drive System (PDS) Efficiency combines both the motor and VFD efficiency.

# Technical Data

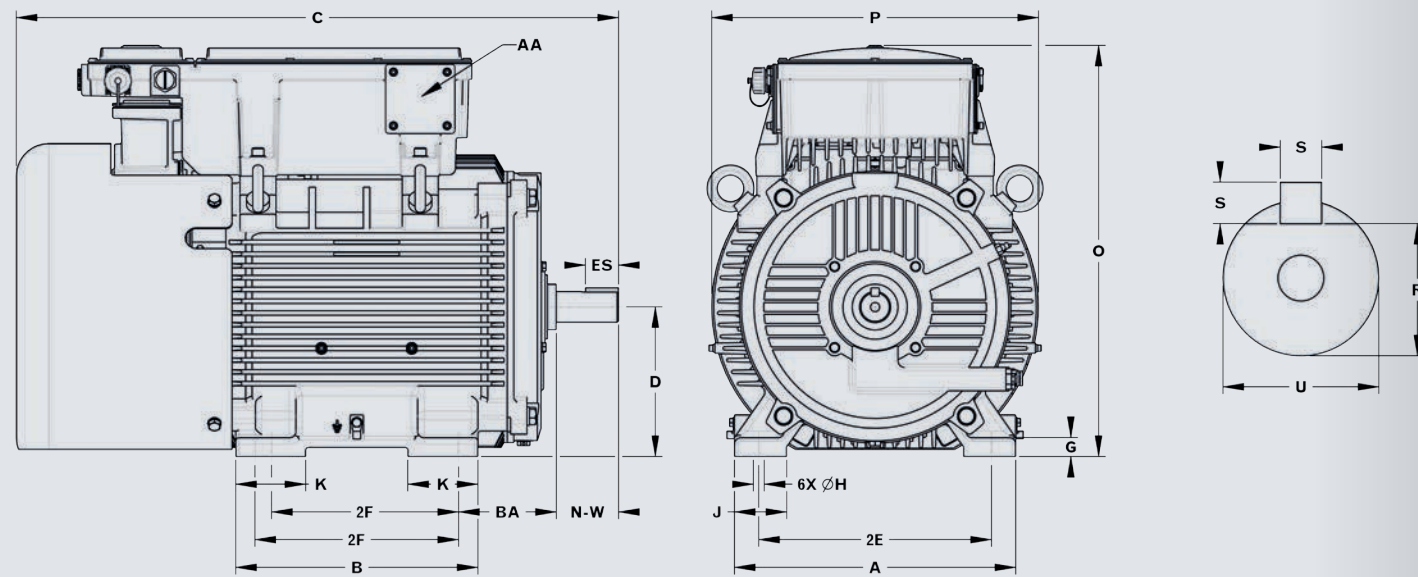

\* Optional F1 or F2 conduit box not shown

## Dimensions

FRAME	2E	2F	H	BA	A	B	C	D	G	J	O	K	P	S	R	ES	N-W	U
254/6T	10.000	8.250 / 10.000	0.530	4.250	12.130	11.810	28.320	6.250	0.740	2.360	18.400	3.740	13.780	0.380	1.416	2.910	4.000	1.625
284/6T	11.000	9.500 / 11.000	0.530	4.750	12.760	12.600	31.670	7.000	0.740	2.360	20.170	3.740	15.590	0.500	1.591	3.280	4.625	1.875
284/6TS	11.000	9.500 / 11.000	0.530	4.750	12.760	12.600	30.030	7.000	0.740	2.360	20.170	3.740	15.590	0.380	1.416	1.910	3.250	1.625
324/6T	12.500	10.500 / 12.000	0.660	5.250	14.880	13.780	35.220	8.000	1.110	2.760	22.870	4.330	17.650	0.500	1.845	3.910	5.250	2.125
324/6TS	12.500	10.500 / 12.000	0.660	5.250	14.880	13.780	33.720	8.000	1.110	2.760	22.870	4.330	17.650	0.500	1.591	2.030	3.750	1.875
364/5T	14.000	11.250 / 12.250	0.660	5.880	16.930	14.570	38.370	9.000	1.140	3.150	24.730	4.210	19.660	0.625	2.020	4.280	5.880	2.375
364/5TS	14.000	11.250 / 12.250	0.660	5.880	16.930	14.570	36.240	9.000	1.140	3.150	24.730	4.210	19.660	0.500	1.591	2.030	3.750	1.875

## Specifications

Load Type:	Variable Torque
Applications:	Pumps, Fans, Blowers, Compressors
Input Voltage:	460V +10% / -5%
Input Harmonic Distortion:	THDi < 5% @ 100% Load
Voltage Imbalance:	±3% phase to phase
Input Frequency:	47-63 Hz
Service Factor:	1.00
Overload:	120% @ 60s / 150% @ 3s
Motor Efficiency:	> NEMA Premium / IE4
PDS Efficiency:	> IES2
Maximum Speed:	2500 RPM / 4500RPM
Minimum Turndown:	10:1
Warranty:	3-years

Operating Temperature:	-25 to 40°C (up to 50°C with derating)
Storage Temperature:	-25 to 65°C
Max Elevation:	1000m (up to 2000m with derating)
Vibration:	IEC 60721-3-3 (2019) 3M11
Motor Frame Material:	Cast Iron
Motor IP Rating:	TEFC - IP55
Terminal Box / VFD Material:	Aluminum
Terminal Box / VFD IP Rating:	IP66
Area Classification:	Class I Division II Groups A,B,C,D T4
EMC Level:	EN55011 (CISPR 11): Class A (industrial): C3
Safety Integrity Level:	IEC61508 SIL2, ISO13849-1 Category 3PL d
Corrosion Testing:	ASTM B-117 Salt Spray, B-845 Meth. K Mixed Gas Corrosion
Standards & Certifications:	UL, CSA, CE

## Others

Starting Method: **Integral Soft Start/Stop**  
 Anti-Condensation: **Integral w/ 460V mains**  
 Speed Feedback Device: **Sensorless**  
 Keypad Interface: **External**

Thermal Device - Winding: **2xKTY84 (1 Primary / 1 Back-Up)**  
 Thermal Device - Converter: **Built-in Temperature Sensor**

Conforms to UL STD 121201 (Full Assembly)  
 Certified to CSA STD C22.2 No 213 (Full Assembly)  
 Conforms to UL STD 61800-5-1 (Converter)  
 Certified to CSA STD C22.2 No. 274 (Converter)  
 UR - UL Recognized (Motor)

Analog Inputs: **2 Inputs (0-10Vdc, 0-20mA, 4-20mA)**  
 Analog Outputs: **2 Outputs (0-20mA, 4-20mA)**  
 Digital Inputs: **6 - 24Vdc**  
 Relay Outputs: **2 - 250VAC/30Vdc 3A**  
 Ethernet Comms.: **Modbus TCP / Ethernet IP**